

EnergyMax - Laser Energy Sensors

Introduction and Selection Charts



Features

- Superior damage resistance
- High repetition rate operation
- Large dynamic range gives each sensor broad coverage
- Low noise and excellent linearity for greater accuracy
- Large active area

EnergyMax Sensors

Coherent EnergyMax sensors enable laser pulse energy measurement over a broad range of wavelengths, repetition rates, pulse energies and beam diameters. With their unique combination of superior performance and user-friendly convenience, EnergyMax sensors are your best choice no matter what your particular laser energy measurement need. EnergyMax sensors are highly linear in terms of repetition rate, laser pulse width, and measured energy. They are also accurate across a broad range of wavelengths due to onboard wavelength compensation. In addition, automatic temperature compensation accounts for

changes in ambient temperature, as well as for heat generated by absorption of the laser energy. Temperature compensation also enables the use of user-installable heat sinks for even higher average power handling capabilities. Coherent EnergyMax sensors are the most linear and accurate on the market.

Fundamental Principles

Unlike all other thermal detectors, pyroelectrics measure the rate of change of the detector temperature, rather than the temperature value itself. As a result, the response speed of the pyroelectric is usually limited by its electrical circuit design and the thermal resistance of the absorptive coating. In contrast, other thermal detectors (such as thermopiles and bolometers) are limited by slower thermal response speeds, typically on the order of seconds. Pyroelectrics respond only to changing radiation that is chopped, pulsed, or otherwise modulated, so they ignore steady background radiation that is not changing with time. Their combination of wide uniform spectral response, sensitivity, and high speed makes pyroelectrics ideal choices for a vast number of electro-optic applications.

The EnergyMax sensor line uses a pyroelectric element to measure the energy in a laser pulse. It does this by producing a large electrical charge for a small change in temperature. The active sensor circuit takes the current from the sensor element and converts it to a voltage that the instrument can measure.

The figure below shows the relationship between the current response of the pyroelectric element and the output voltage of the sensor circuit. The relationship between the current response and the output voltage response is fixed so that the calibrated peak voltage of the output is the integrated energy of the laser pulse. Refer to the User Manual for information on Quantum EnergyMax sensors.

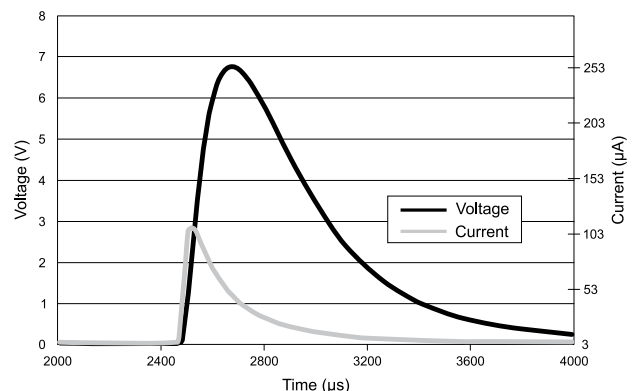

EnergyMax - Laser Energy Sensors

Introduction and Selection Charts

All pyroelectric EnergyMax sensors incorporate a diffuse coating to minimize specular reflections and eliminate spurious beams that can re-enter the laser cavity. In addition, all EnergyMax sensors include onboard electronics that contain built-in wavelength compensation factors. When using the sensor with a meter such as LabMax or FieldMaxII, enter the wavelength of the laser being measured into the meter and this will automatically compensate for the sensor output. The chart below plots the typical absorption percentage of each coating.

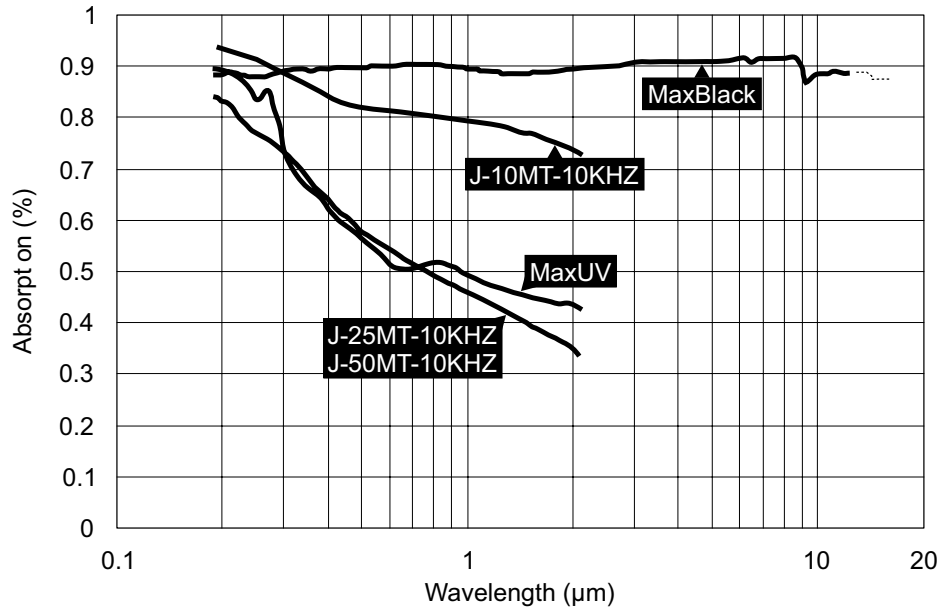

J-25MT-10KHZ with Medium Heat Sink

Meter Compatibility Chart	LabMax-TOP	FieldMaxII-TOP & -P	EPM2000
All J-10MB-, J-25MB-, J-50MB-, J-25MUV-, J-50MUV-EnergyMax Models	•	•	•
J-10MT-10KHZ, J-25MT-10KHZ, J-50MT-10KHZ EnergyMax Models	•		•
J-10SI- and J-10GE Quantum EnergyMax Models	•		•

Explanation of Part Numbers

EnergyMax part numbers are “Smart” part numbers that have the following meaning:

J –	Active Area Diameter 10, 25, or 50 mm	Coating Type MT for Diffuse Metallic MB for MaxBlack MUV for MaxUV	–	Descriptive Suffix LE for Low Energy HE for High Energy 10 KHZ for Max. Rep. Rate 193 and 248 Calibrated Wavelength
------------	---	--	----------	--

J: Represents an energy sensor

Example: J-10MB-LE is an energy sensor with a 10 mm active area diameter MaxBlack coating for low energy measurements

- POWER & ENERGY
- Power & Energy Meters
- Power Sensors
- Energy Sensors
- Custom & OEM
- BEAM DIAGNOSTICS
- CALIBRATION & SERVICE
- Laser Cross-Reference Index
- Model Name Index

EnergyMax - Laser Energy Sensors

Applying Wavelength Compensation Accuracy

Overall measurement accuracy is a combination of calibration uncertainty (found in the sensor specification tables) and the wavelength compensation accuracy (found in the “Wavelength Compensation Accuracy” table, below).

The combined accuracy is based upon practices outlined in the National Institute of Standards Guidelines for Evaluating and Expressing Uncertainty (NIST Technical Note 1297, 1994 Edition). The combined accuracy of the measurement is calculated by using the law of propagation of uncertainty using the “root-sum-of-square” (square root of the sum of squares), sometimes described as “summing in quadrature” where:

$$\text{Measurement Accuracy} = \sqrt{U^2 + W^2}$$

where U = ‘Percent Calibration Uncertainty’ and W = ‘Wavelength Accuracy’

Example 1

J-10SI-HE used at 355 nm

$$U = 3\%$$

$$W = 5\%$$

$$\text{Measurement Accuracy} = \sqrt{3^2 + 5^2} = \sqrt{9 + 25} = 5.8\%$$

Example 2

J-10MB-LE used at 532 nm

$$U = 2\%$$

$$W = 2\%$$

$$\text{Measurement Accuracy} = \sqrt{2^2 + 2^2} = \sqrt{4 + 4} = 2.8\%$$

Wavelength Compensation Accuracy	Model	Wavelength Compensation Accuracy (%) (for wavelengths other than the calibration wavelength)	Calibration Wavelength (nm)
	All Multipurpose Sensors (MaxBlack Coating)	±2	1064
	All High Repetition Rate Sensors (Diffuse Metallic Coating)	±3	1064
	J-50MB-YAG	±2	1064
	J-50MB-IR	±3	1064, 2940
	J-25MB-IR	±4	1064
	J-25MUV-193	±3	193
	J-25MUV-248	±3	248
	J-50MUV-193	±4	193
	J-50MUV-248	±4	248
	J-10SI-LE	±5	532
	J-10SI-HE	±5	532
	J-10GE	±5	1064

EnergyMax - Laser Energy Sensors

Introduction and Selection Charts

The next selection chart shows the range of wavelengths that can be measured with each sensor. This characteristic is coating dependent, so sensors with diffusers may have a narrower spectral range than similar sensors without diffusers.

The spectral compensation of each sensor is unique to that serial number, and is based upon spectral scans performed on each sensor disk (and on each optic if the sensor has a diffuser). The spectral compensation provides greater measurement accuracy for wavelengths that differ from the optical calibration wavelength.

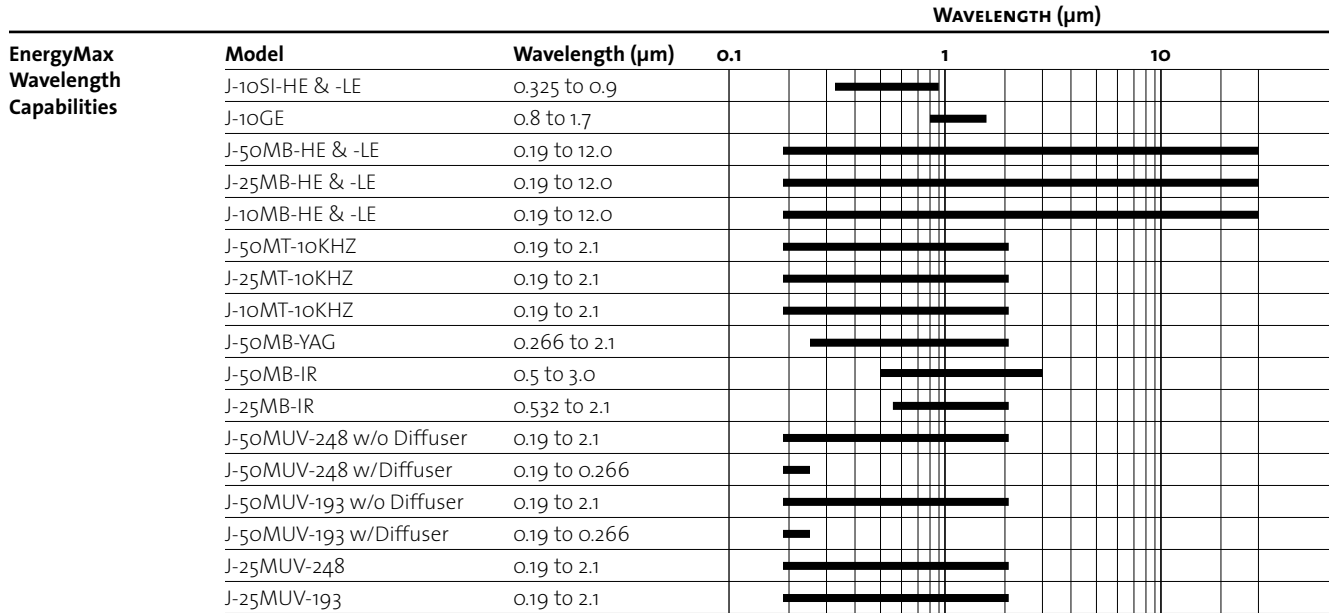

EnergyMax sensors are based upon pyroelectric technology and can therefore measure lasers at high repetition rates. The maximum repetition rate is primarily dependent upon the thermal resistance of the coating and the maximum pulse width the sensor is designed to measure. Refer to the summary table on page 8 for maximum laser pulse width limitations.

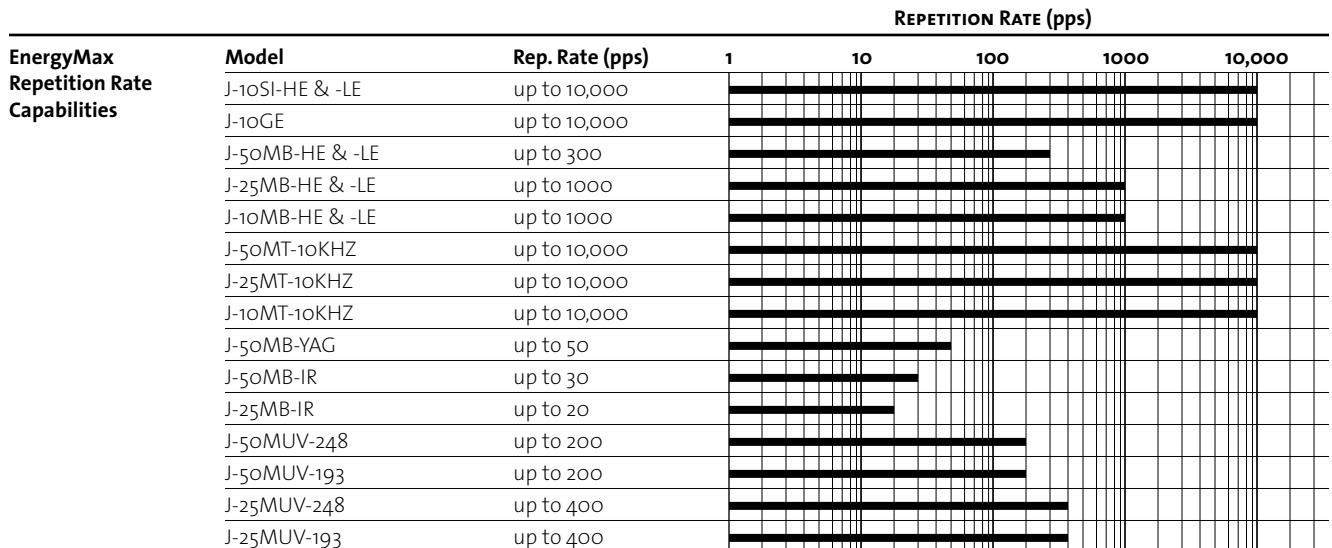

EnergyMax - Laser Energy Sensors

Energy Sensor Summary Specifications

Before using a sensor, it is important to ensure that the laser beam will not damage the sensor coating. The damage threshold is also wavelength dependent, and maximum energy density thresholds are listed for common laser wavelengths in the table below. At other wavelengths it is safe to interpolate between the listed values.

EnergyMax Damage Threshold Capabilities ¹	Model	Damage Threshold (mJ/cm ²)					
		193 nm	248 nm	266 nm	355 nm	532 nm	1064 nm
	J-50MB-HE	40	170	170	140	250	500
	J-50MB-LE	40	170	170	140	250	500
	J-25MB-HE	40	170	170	140	250	500
	J-25MB-LE	40	170	170	140	250	500
	J-10MB-HE	40	170	170	140	250	500
	J-10MB-LE	40	170	170	140	250	500
	J-50MT-10KHZ	150	200	200	390	500	500
	J-25MT-10KHZ	150	200	200	390	500	500
	J-10MT-10KHZ	40	40	40	50	50	50
	J-50MB-YAG	–	–	1000	750	2800	14,000
	J-25MB-IR	–	–	–	–	1500	5000
	J-50MUV-248 w/o Diffuser	200	260	260	300	375	375
	J-50MUV-248 w/Diffuser	400	520	520	–	–	–
	J-50MUV-193 w/o Diffuser	200	260	260	300	375	375
	J-50MUV-193 w/Diffuser	400	520	520	–	–	–
	J-25MUV-248	200	260	260	300	375	375
	J-25MUV-193	200	260	260	300	375	375

¹ Not applicable for Quantum EnergyMax sensors.

The table below shows the key specifications for each sensor. Additional specifications can be found on pages 58 to 62.

Part Number Wavelength	Description	Wavelength Range (µm)	Min. Energy	Max. Energy	Max. Average Power (W)				Max. Rep. Rate (pps)	Max. Pulse Width (µs)	Active Area Dia. (mm)	Detector Coating	Diffuser	Calibration
					No H.S. ¹	Small H.S.	Med. H.S.	Large H.S.						
1110573	J-50MB-HE	0.19 to 12	1 mJ	2J	10	–	–	24	300	57	50	MaxBlack	None	1064
1110576	J-50MB-LE	0.19 to 12	250 µJ	500 mJ	10	–	–	24	300	57	50	MaxBlack	None	1064
1110746	J-25MB-HE	0.19 to 12	500 µJ	1J	5	10	15	–	1000	17	25	MaxBlack	None	1064
1110743	J-25MB-LE	0.19 to 12	25 µJ	50 mJ	5	10	15	–	1000	17	25	MaxBlack	None	1064
1110843	J-10MB-HE	0.19 to 12	10 µJ	20 mJ	4	–	–	–	1000	17	10	MaxBlack	None	1064
1110855	J-10MB-LE	0.19 to 12	300 nJ	600 µJ	4	–	–	–	1000	17	10	MaxBlack	None	1064
1110574	J-50MT-10KHZ	0.19 to 2.1	500 µJ	1J	20	–	–	49	10000	1.7	50	Diff. Met. ²	None	1064
1110747	J-25MT-10KHZ	0.19 to 2.1	50 µJ	100 mJ	10	20	31	–	10000	1.7	25	Diff. Met.	None	1064
1110856	J-10MT-10KHZ	0.19 to 2.1	100 nJ	200 µJ	1	–	–	–	10000	1.7	10	Diff. Met.	None	1064
1110744	J-50MB-YAG	0.266 to 2.1	1.5 mJ	3J	20	–	–	48	50	340	50	MaxBlack	YAG	1064
1155722	J-50MB-IR	0.5 to 3	1 mJ	3J	15W	–	–	–	30	1000	50	MaxBlack	IR	1064, 2940
1110577	J-25MB-IR	0.532 to 2.1	1.5 mJ	3J	20	41	62	–	20	860	25	MaxBlack	IR	1064
1146243	J-50MUV-248 w/o Diffuser	0.19 to 2.1	500 µJ	1J	10	–	–	25	200	86	50	MaxUV	None	248
1110572	J-50MUV-248 w/Diffuser	0.19 to 0.266	500 µJ	1J	15	–	–	36	200	86	50	MaxUV	DUV	248
1146237	J-50MUV-193 w/o Diffuser	0.19 to 2.1	125 µJ	250 mJ	10	–	–	30	200	86	50	MaxUV	None	193
1110575	J-50MUV-193 w/Diffuser	0.19 to 0.266	125 µJ	250 mJ	18	–	–	43	200	86	50	MaxUV	DUV	193
1110745	J-25MUV-248	0.19 to 2.1	125 µJ	250 mJ	5	10	16	–	400	43	25	MaxUV	None	248
1110741	J-25MUV-193	0.19 to 2.1	50 µJ	100 mJ	5	10	15	–	400	43	25	MaxUV	None	193
1150146	J-10SI-HE	0.325 to 0.9	60 pJ ³	775 nJ ³	60 mW	–	–	–	10000	1	10	Silicon	ND2	532
1140727	J-10SI-LE	0.325 to 0.9	8 pJ ³	80 nJ ³	6 mW	–	–	–	10000	1	10	Silicon	ND2	532
1140408	J-10GE	0.8 to 1.7	200 pJ ⁴	600 nJ ⁴	15 mW	–	–	–	10000	1	10	Germanium	ND2	1064

¹ Heat Sink.

² Diffuse metallic.

³ At 532 nm.

⁴ At 1064 nm.

- POWER & ENERGY
- Power & Energy Meters
- Power Sensors
- Energy Sensors
- Custom & OEM
- BEAM DIAGNOSTICS
- CALIBRATION & SERVICE
- Laser Cross-Reference Index
- Model Name Index

EnergyMax Sensors

MaxBlack Coating



J-50MB-HE, J-25MB-HE, J-10MB-HE

Features

- Unique MaxBlack coating increases damage threshold, allows high repetition rate operation, and improves mechanical durability
- Operate over the 190 nm to 12 μm range
- Enable pulse energy measurements from 300 nJ to 2J with high signal-to-noise characteristics
- Measure single shot to 1 kHz repetition rate
- Spectral compensation characteristics built into each unit
- Onboard sensors provide automatic temperature compensation

These sensors allow measurements over a wide range of wavelengths, beam diameters, average power levels, and repetition rates. The MaxBlack coating on these sensors provides significant damage resistance and mechanical durability characteristics compared to the black paint coatings often used on broadband sensors in the past.

Device Specifications	Model	J-50MB-HE	J-50MB-LE	J-25MB-HE	J-25MB-LE	J-10MB-HE	J-10MB-LE
Energy Range		1 mJ to 2J	250 μJ to 500 mJ	500 μJ to 1J	25 μJ to 50 mJ	10 μJ to 20 mJ	300 nJ to 600 μJ
Noise Equivalent Energy		<33 μJ	<8 μJ	<16 μJ	<1 μJ	<0.5 μJ	<20 nJ
Wavelength Range (μm)		0.19 to 12					
Active Area Diameter (mm)		50	50	25	25	10	10
Maximum Average Power (W) ¹		10	10	5	5	4	4
Maximum Pulse Width (μs)		57		17			
Maximum Repetition Rate (pps)		300	300	1000	1000	1000	1000
Maximum Energy Density (mJ/cm ²)		500 (at 1064 nm, 10 ns)					
Detector Coating		MaxBlack					
Diffuser		No					
Calibration Wavelength (nm)		1064					
Calibration Uncertainty (%)		±2					
Energy Linearity (%)		±3					
Cable Length (m) ²		2.5					
Cable Type		J DB-25					
Part Number		1110573	1110576	1110746	1110743	1110843	1110855

¹ Extend average power range with optional heat sink. See page 55 and 64.

² Cable lengths up to 10m possible. Contact factory.

J-25MB-HE and -LE

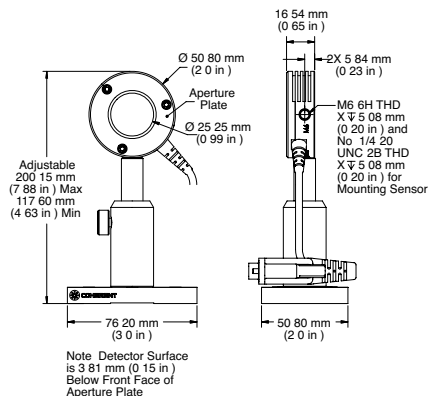

J-50MB-HE and -LE

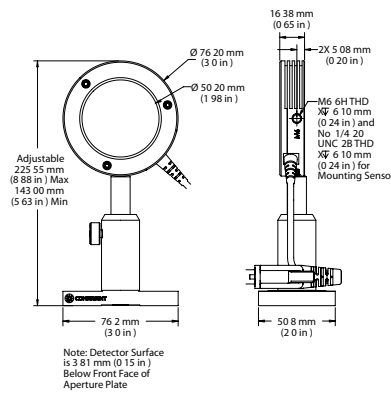

J-10MB-HE and -LE

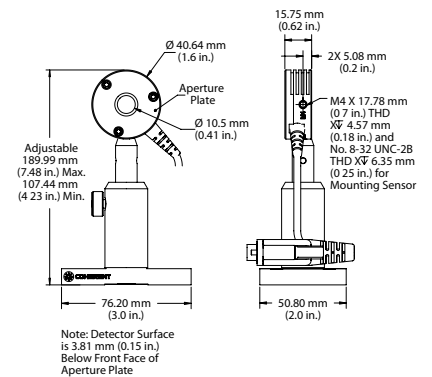

EnergyMax Sensors

Diffuse Metallic Coating



J-50MT-10KHZ, J-25MT-10KHZ, J-10MT-10KHZ

Features

- Unique diffuse metallic coating delivers increased damage threshold, allows high repetition rate operation and reduces specular reflectance
- Operate over the entire 190 nm to 2.1 μm range
- Enable pulse energy measurements from 100 nJ to 1J with high signal-to-noise characteristics
- Measure up to 10 kHz repetition rate
- Spectral compensation characteristics built into each unit
- Onboard sensors provide automatic temperature compensation¹

These sensors use a diffuse metallic coating that enables measurements at high and low repetition rates across a wide range of energies, wavelengths and beam sizes. The damage resistance at 532 nm and shorter wavelengths is even greater than the MaxBlack coating. These are great all-purpose sensors for the 190 nm to 2.1 μm region and offer the lowest energy range of our EnergyMax line.

Device Specifications	Model	J-50MT-10KHZ	J-25MT-10KHZ	J-10MT-10KHZ
Energy Range		500 μJ to 1J ²	50 μJ to 100 mJ	100 nJ to 200 μJ
Noise Equivalent Energy		<16 μJ	<2 μJ	<10 nJ
Wavelength Range (μm)		0.19 to 2.1		
Active Area Diameter (mm)		50	25	10
Maximum Average Power (W) ³		20	10	1
Maximum Pulse Width (μs)		1.7		
Maximum Repetition Rate (pps)		10,000		
Maximum Energy Density (mJ/cm ²)		500 (at 1064 nm, 10 ns)		50 (at 1064 nm, 10 ns)
Detector Coating		Diffuse Metallic		
Diffuser		No		
Calibration Wavelength (nm)		1064		
Calibration Uncertainty (%)		± 2		
Energy Linearity (%)		± 3		
Cable Length (m) ⁴		2.5		
Cable Type		J DB-25		
Part Number		1110574	1110747	1110856

¹ Except J-10MT-10KHZ.

² Optional energy range 50 μJ to 100 mJ available.

³ Extend average power range with optional heat sink. See page 55 and 64.

⁴ Cable lengths up to 10m possible. Contact factory.

J-50MT-10KHZ

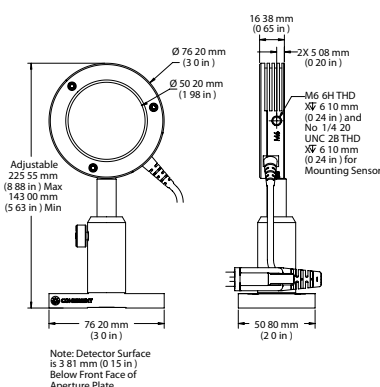

J-25MT-10KHZ

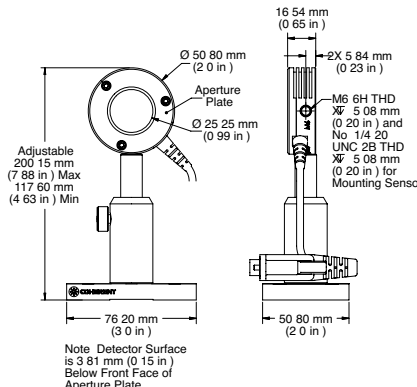

J-10MT-10KHZ

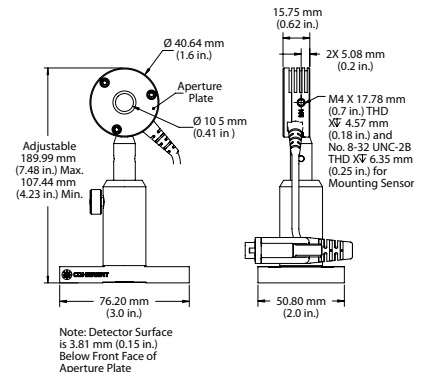

Toll Free: (800) 343-4912

Tel: (408) 764-4042

Fax: (503) 454-5727

POWER & ENERGY

Power & Energy Meters

Power Sensors

Energy Sensors

Custom & OEM

BEAM DIAGNOSTICS

CALIBRATION & SERVICE

Laser Cross-Reference Index

Model Name Index

EnergyMax Sensors

MaxBlack Coating and Diffusers



J-50MB-YAG and J-25MB-IR

Features

- High energy and peak power to 14 J/cm²
- Operate at Nd:YAG fundamental and harmonics, and throughout the IR
- Enable pulse energy measurements from 1 mJ to 15J¹
- Spectral compensation characteristics built into each unit
- Onboard sensors provide automatic temperature compensation
- No need to either change diffusers during use or perform your own spectral calibrations

These sensors are specifically designed for high energy and high peak power lasers operating at relatively low repetition rates, such as those based on Nd:YAG, Ruby, Ho:YAG and Erbium. The J-50MB-YAG sensor can be used with beams up to 35 mm in diameter and can work at 1064 nm, 532 nm, 355 nm and 266 nm without the need to change or self-calibrate diffusers or any other accessories. Both sensors combine a MaxBlack coating and a diffuser to produce superior damage resistance characteristics. This combination enables operation with lasers that produce either very high energy per pulse or very high peak fluences.

Device Specifications	Model	J-50MB-YAG	J-50MB-IR	J-25MB-IR
Energy Range		1.5 mJ to 3J ¹	1.0 mJ to 3J	1.5 mJ to 3J
Noise Equivalent Energy (μJ)		<50	<100	<50
Wavelength Range (μm)		0.266 to 2.1	0.5 to 3.0	0.532 to 2.1
Maximum Beam Size (mm)		35	30	12.5
Maximum Average Power (W) ²		20	15	20
Maximum Pulse Width (μs)		340	1000	860
Maximum Repetition Rate (pps)		50	30	20
Maximum Energy Density (J/cm ²)		14.0 (at 1064 nm, 10 ns) 2.8 (at 532 nm, 10 ns) 0.75 (at 355 nm, 10 ns) 1.0 (at 266 nm, 10 ns)	>100 (at 2940 nm, 100 μs)	5.0 (at 1064 nm, 10 ns)
Detector Coating		MaxBlack	MaxBlack	MaxBlack
Diffuser		YAG	IR	IR
Calibration Wavelength (nm)		1064	1064, 2940	1064
Calibration Uncertainty (%)		±2	±2	±3
Energy Linearity (%)		±3	±3.5	±3
Cable Length (m) ³		2.5	2.5	2.5
Cable Type		J DB-25	J DB-25	J DB-25
Part Number		1110744	1155722	1110577

¹ Modified sensors with higher repetition rate, energy range and/or pulse width are available. Contact factory.

² Extend average power range with optional heat sink. See page 55 and 64.

³ Cable lengths up to 10m possible. Contact factory.

J-50MB-YAG and -IR

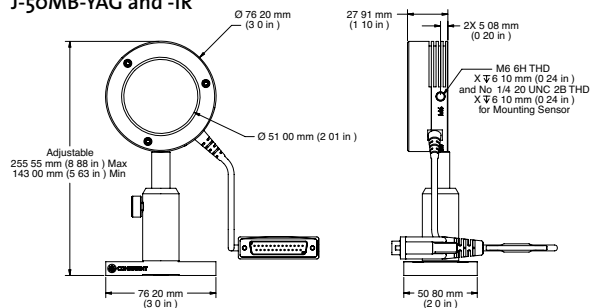

J-25MB-IR

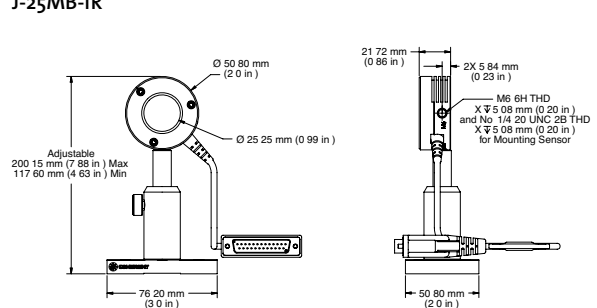

EnergyMax Sensors

MaxUV Coating



J-50MUV-248 and J-25MUV-248

Features

- Unique MaxUV coating delivers highest DUV damage threshold and long-term UV exposure resistance
- Operate over the 190 nm to 2.1 μm range
- Enable pulse energy measurements from 50 μJ to 1J
- Measure up to 400 Hz repetition rate
- Spectral compensation characteristics built into each unit
- Onboard sensors provide automatic temperature compensation

MaxUV-coated EnergyMax sensors are specifically optimized for use with ArF lasers operating at 193 nm and KrF lasers at 248 nm. These sensors feature high accuracy and large active areas (up to 50 mm), and use a unique coating called MaxUV that delivers superior long-term damage resistance.

Two of the 50 mm diameter models incorporate a DUV quartz diffuser for increased resistance to coating damage.

Device Specifications	Model	J-50MUV-248	J-50MUV-248	J-50MUV-193	J-50MUV-193	J-25MUV-248	J-25MUV-193
		w/o Diffuser	w/Diffuser	w/o Diffuser	w/Diffuser	w/o Diffuser	w/o Diffuser
Energy Range		500 μJ to 1J	500 μJ to 1J	125 μJ to 250 mJ	125 μJ to 250 mJ	125 μJ to 250 mJ	50 μJ to 100 mJ
Noise Equivalent Energy (μJ)		<16	<16	<4	<4	<4	<2
Wavelength Range (μm)		0.19 to 2.1	0.19 to 0.266	0.19 to 2.1	0.19 to 0.266	0.19 to 2.1	0.19 to 2.1
Active Area Diameter (mm)		50	50	50	50	25	25
Max. Average Power (W) ¹		10	15	10	18	5	5
Max. Pulse Width (μs)		86	86	86	86	43	43
Max. Rep. Rate (pps)		200	200	200	200	400	400
Max. Energy Density (mJ/cm ²)		260 (at 248 nm, 10 ns)	520 (at 248 nm, 10 ns)	200 (at 193 nm, 10 ns)	400 (at 193 nm, 10 ns)	260 (at 248 nm, 10 ns)	200 (at 193 nm, 10 ns)
Detector Coating		MaxUV					
Diffuser		No	DUV	No	DUV	No	No
Calibration Wavelength (nm)		248	248	193	193	248	193
Calibration Uncertainty (%)		± 3					
Energy Linearity (%)		± 3					
Cable Length (m) ²		2.5					
Cable Type		J DB-25					
Part Number		1146243	1110572	1146237	1110575	1110745	1110741

¹ Extend average power range with optional heat sink. See page 55 and 64.

² Cable lengths up to 10m possible. Contact factory.

J-50MUV-248 and -193

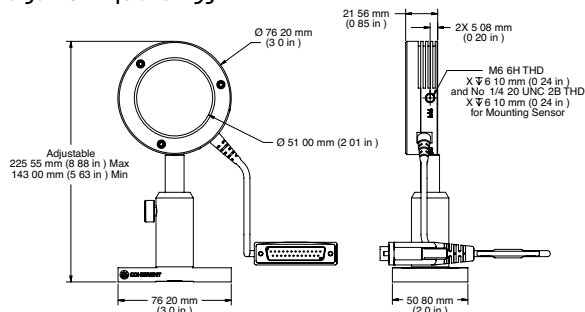

J-25MUV-248 and -193

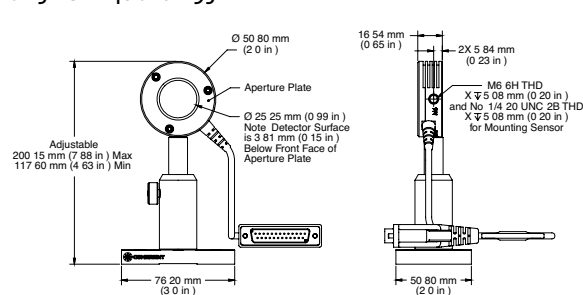

EnergyMax Sensors

Quantum Series

POWER & ENERGY

Power & Energy Meters

Power Sensors

Energy Sensors

Custom & OEM

BEAM DIAGNOSTICS

CALIBRATION & SERVICE

Laser Cross-Reference Index

Model Name Index



J-10SI-LE

Features

- Pulse energy measurement down to 8 pJ (within line; model dependent)
- Average power measurement of pulsed sources from nW to mW level signal-to-noise characteristics
- Measures single pulses to 10,000 Hz
- Accurate spectral compensation
 - 325 nm to 900 nm for Silicon
 - 800 nm to 1700 nm for Germanium
- Robust and reliable construction

Quantum EnergyMax sensors enable low energy pulse measurements down to the 8 pJ level, as well as average power of pulsed systems from the nW to mW level, across a broad range of wavelengths. These sensors have a removable light shield on the front used to block stray light.

Device Specifications	Model	J-10SI-LE	J-10SI-HE	J-10GE
Energy Range		8 pJ to 80 nJ (@ 532 nm)	60 pJ to 775 nJ (@ 532 nm)	200 pJ to 600 nJ (@ 1064 nm)
Noise Equivalent Energy		<0.8 pJ (@ 532 nm)	<6 pJ (@ 532 nm)	<8 pJ (@ 1064 nm)
Wavelength Range (nm)		325 to 900	325 to 900	800 to 1700
Active Area Diameter (mm)		10	10	10
Max. Avg. Power (mW)		6	60	15
Max. Pulse Width (μs)		1	1	1
Max. Rep. Rate (pps)		10,000	10,000	10,000
Sensor		Silicon	Silicon	Germanium
Diffuser		ND2	ND2	ND2
Calibration Wavelength (nm)		532	532	1064
Calibration Uncertainty (%)		±3	±3	±3
Linearity (%)		±3	±3	±3
Cable Length (m) ¹		3	3	3
Cable Type		J DB-25	J DB-25	J DB-25
Part Number		1140727	1150146	1140408

¹ Cable lengths up to 10m possible. Contact factory.

J-10SI-LE and -HE/J10GE

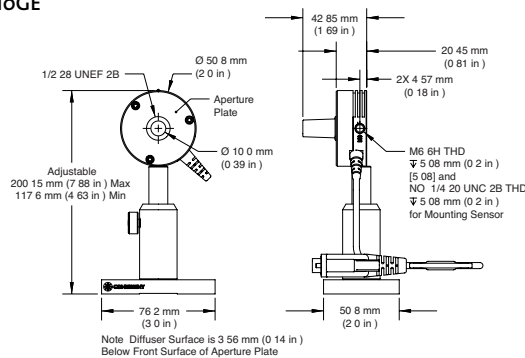

EnergyMax Sensors

Quantum Series

The Quantum EnergyMax series consists of three different models that provide very low pulse energy measurement down to 20 pJ. Two of the models (J-10Si-LE and J-10Si-HE) incorporate a Silicon photodiode, and one model (J-10Ge) incorporates a Germanium photodiode. All three models contain large 10 mm clear apertures and operate at repetition rates from single pulse up to 10 kHz.

The main difference between Quantum EnergyMax sensors and other Coherent EnergyMax sensors is their sensitivity. Quantum EnergyMax sensors are capable of measuring considerably smaller signals than the rest of the EnergyMax sensor line. They do this by utilizing a photodiode—rather than a pyroelectric—element.

Due to the quantum nature of their response, photodiode sensors are inherently more sensitive than pyroelectric sensors, which are thermal-based. One consequence of this extra sensitivity is the possibility of measurement error or noise from stray modulated light sources (for example, stray reflections or room lights) in a laboratory environment. For this reason Quantum EnergyMax sensors are designed for use with a small integrated input beam tube, which limits the field of view of the sensor aperture. This tube is removable for alignment purposes and custom applications.

The following chart plots the minimum and maximum measurable energy of each sensor across all wavelengths. This chart can be used to determine the measurable energy range for wavelengths other than those in the specifications table (1064 nm and 532 nm).



LabMax-TOP and J-10Si-LE

- POWER & ENERGY
- Power & Energy Meters
- Power Sensors
- Energy Sensors
- Custom & OEM
- BEAM DIAGNOSTICS
- CALIBRATION & SERVICE
- Laser Cross-Reference Index
- Model Name Index

Spectral Sensitivity Curves for Quantum EnergyMax Sensors

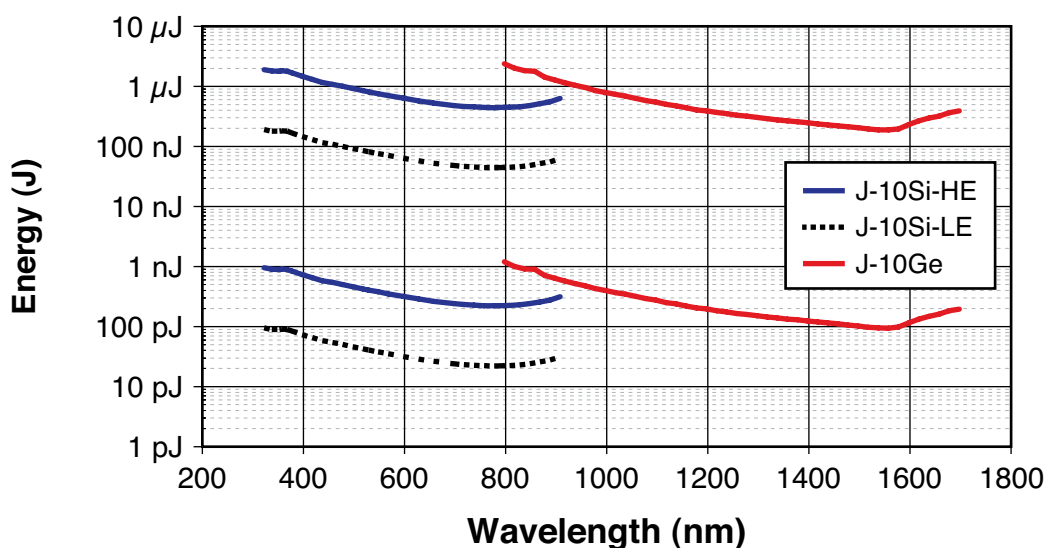

EnergyMax Accessories

Heat Sinks



EnergyMax Heat Sinks

Features

- Extend EnergyMax average power
- Easily attach to EnergyMax sensors in the field
- Two heat sinks for 25 mm sensors (small and medium)
- One heat sink for 50 mm sensors (large)

These heat sink accessories can be used to extend the energy and repetition rates of EnergyMax sensors by increasing the average power capability. Easily installed, they are simply threaded onto the back of a sensor housing with a cap screw retained within the heat sink.

The small and medium models, for use with sensors that have a 25 mm diameter aperture, increase the average power handling into the 10W to 30W range (coating and wavelength dependent). The large heat sink, for use with 50 mm diameter aperture sensors, increases the average power handling into the 20W to 40W range (coating and wavelength dependent). See Average Power Capability table on page 55 for sensor specifications.

Small Heat Sink

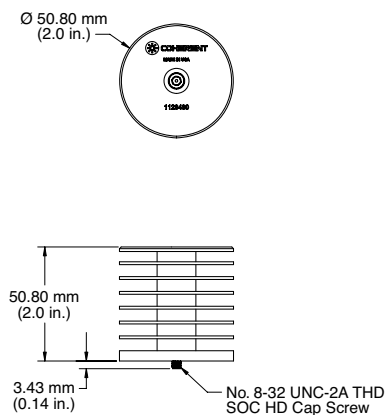

Medium Heat Sink

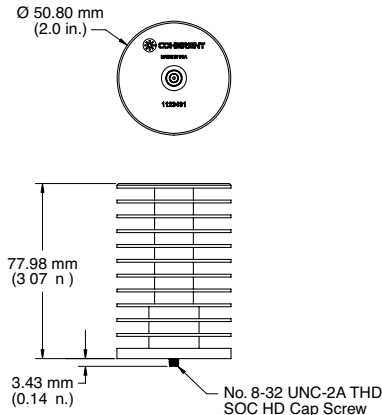

Large Heat Sink

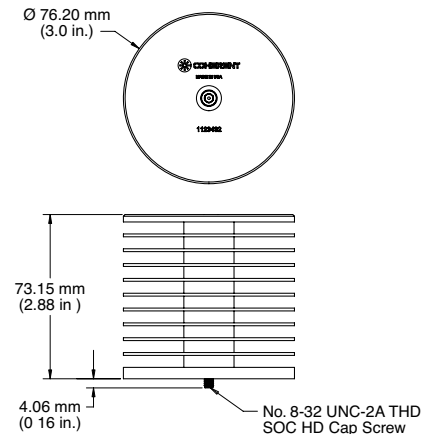

Part Number	Description
1123430	Small Heat Sink
1123431	Medium Heat Sink
1123432	Large Heat Sink

EnergyMax Accessories

J-Power Energy Sensor DB-25-to-BNC Adapter



J-Power

The J-Power is a compact sensor adapter that powers the EnergyMax active sensor circuit and passes the raw output voltage of the sensor directly to the BNC connector. The peak voltage of the output (as referenced from baseline voltage) can then be measured using an oscilloscope or other analog-to-digital input device. The calibrated peak voltage represents the integrated energy of the laser pulse.

Part Number	Description
1132205	J-Power Energy Sensor Adapter

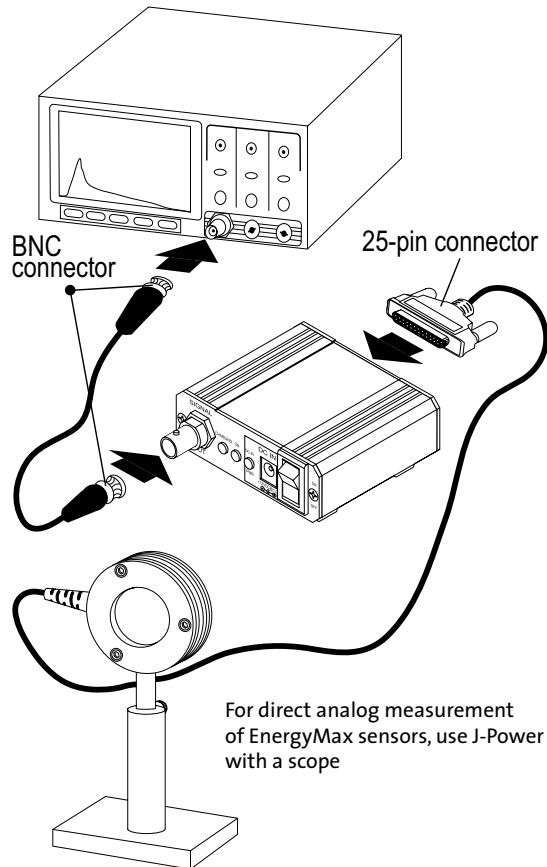

- POWER & ENERGY
- Power & Energy Meters
- Power Sensors
- Energy Sensors
- Custom & OEM
- BEAM DIAGNOSTICS
- CALIBRATION & SERVICE
- Laser Cross-Reference Index
- Model Name Index

Pyroelectric Sensor Test Slides



Test Slides

For protection of your sensor when measuring unknown beams, the test slide is inserted into the beam and then examined for damage. These test slides are coated with the same absorbing coating as the pyroelectric sensors. If coating damage is visible, then attenuation is required before measuring the beam.

Part Number	Description
0011-4311	Pyroelectric Test Slide – Black Coating (used with legacy sensors)
1129175	Pyroelectric Test Slide – Diffuse Metallic Coating
0011-4313	Pyroelectric Test Slide – MUV Coating
0011-4314	Pyroelectric Test Slide – MB Coating

EnergyMax - Laser Energy Sensors

Measuring Energy with an Oscilloscope

To measure the energy of very high repetition rate and/or low-energy lasers, an oscilloscope can be used to monitor the output of an EnergyMax sensor.

This page presents a step-by-step procedure for setting up an oscilloscope and using a pyroelectric EnergyMax sensor to accurately read a peak voltage output.

1. To assure the accuracy of a pulse energy measurement, make sure the oscilloscope is calibrated properly. Also check the date for when the oscilloscope is due for recalibration.
2. Select a scope that has a sensitivity of at least 2 mV and a bandwidth of at least 20 MHz.
3. To connect an EnergyMax sensor to an oscilloscope you will need a J-POWER DB25-to-BNC accessory (available from Coherent).
4. Use the 1 Mohm input impedance of the oscilloscope when connecting any EnergyMax sensor.
5. Set up the scope as follows:
 - Bandwidth to 20 MHz
 - DC coupling
 - Trigger on “+” slope and “internal” source, or use the laser sync output and “external” source
6. Estimate the approximate EnergyMax sensor voltage output expected, based on the R_v (V/I) of the sensor (available on both the calibration certificate and the calibration sticker attached to the sensor cable), and the typical laser pulse energy.
7. If you know your expected laser pulse repetition rate, set the scope time base to show 2 pulses on the screen. This helps set the trigger and allows observation of the true “baseline” of the pulse. For example, for a laser running at 10 pps, set the scope time base to 20 msec/division. Once proper triggering occurs, use the vertical adjust to set the baseline of the EnergyMax voltage pulse to coincide with a horizontal grid line (see Figure 1).
8. Adjust the “time base” of the scope to show a single EnergyMax pulse and then focus on the leading edge to accurately read the peak voltage (see Figure 2).

To avoid affecting the calibration of the sensor with a coaxial cable do not lengthen the cable when using the sensor with the oscilloscope.

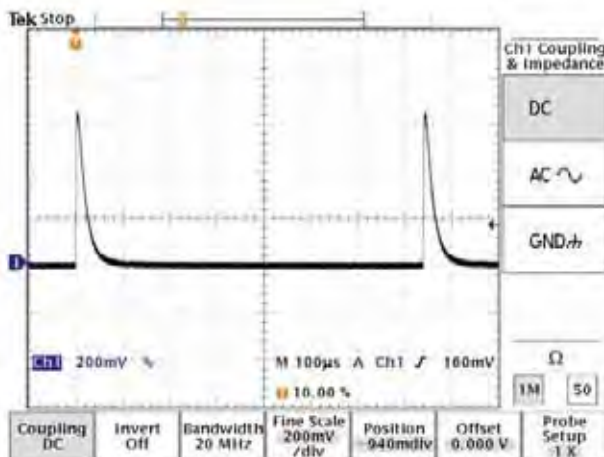

Figure 1

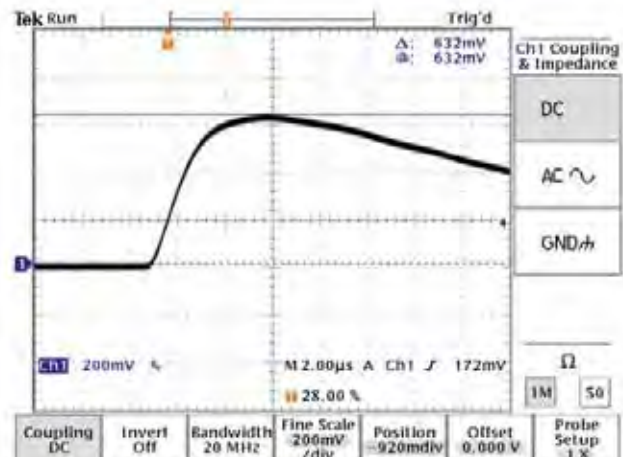

Figure 2

Miscellaneous Energy Sensors

J100 Energy Sensor



J100

Features

- Large-area 95 mm diameter
- Broad spectral response 0.3 to 12 μm
- Wide dynamic range of 0.4 mJ to 5J
- High average power to 20W
- JSA-BNC adapter (1098306) needed for use with FieldMaxII-TOP and LabMax-TOP

The J100 is a pyroelectric energy sensor with a flat, broad spectral response calibrated at 1064 nm. The 95 mm diameter active area is ideal for divergent sources and pulsed lasers used in applications such as laser range finding. The sensor output is through a BNC connector and the product ships with a 1.5 m BNC cable.

Device Specifications	Model	J100
Wavelength Range (μm)		0.3 to 12
Energy Range ¹		0.4 mJ to 5J
Max. Avg. Power		20
Typical Response (Rv) (V/J)		3
Max. Rep. Rate (pps)		50
Max. Pulse Width (μs)		200
Detector Coating		Black
Detector Diameter (mm)		95
Dimensions (mm)		\varnothing 153 x 65
Calibration Uncertainty (%)		\pm 2
Calibration Wavelength (nm)		1064
Connector Type		BNC
Cable Length (m)		1.5 (separate)
Part Number		0011-6100

¹ Maximum energy is pulse-width dependent.

J100

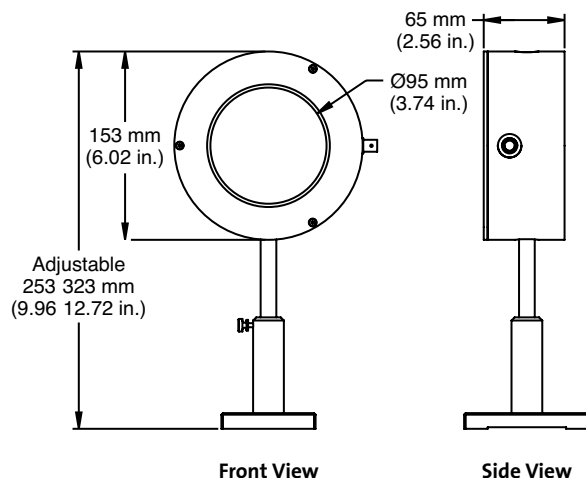

- POWER & ENERGY
- Power & Energy Meters
- Power Sensors
- Energy Sensors
- Custom & OEM
- BEAM DIAGNOSTICS
- CALIBRATION & SERVICE
- Laser Cross-Reference Index
- Model Name Index